

Body - Sunroof Water Leak

NO: 83-34

DATE: 9-2-2005

MODEL: XC90 (03-)

M. YEAR: MY03 -

SUBJECT: Water Leak from Sunroof, Fault Tracing and Service.

REFERENCE: VADIS

This Tech Note supersedes the previous 83-34 dated 2-18-05. Please update your files.

Update is to correct an incorrect Labor Op number.

DESCRIPTION:

Several root causes have been found for possible water leakage from the sunroof.

This TNN describes fault tracing and service methods for the most common problems.

<i>Symptom or customer complaint</i>	<i>Possible root cause</i>	<i>Check (in logical order)</i>	<i>Method/service</i>
<ul style="list-style-type: none">> Floor carpets wet.> Windows fog up quickly.> Car interior is damp.> Water can be heard.> Water dripping from headliner.> Audio module malfunctioning. (due to water damage)> Yaw sensor malfunctioning. (due to water damage)	Sunroof drains clogged.	Check front drainage holes.	STEP 1.1 (see below)
	Incorrect fitting of the sunroof.	Check sunroof fitting.	STEP 1.2 (see below)
	Sound trap not open or clogged.	Check front sound traps.	STEP 1.3 (see below)
	Drainage hose kinked, clogged or loose.	Check front drainage hoses.	STEP 1.4 (see below)
	Drainage hose loose or kinked.	Check connection drainage hose	STEP 1.5 (see below)
	Other: AC drainage, front windshield,...	Continue with fault tracing	According VADIS
<ul style="list-style-type: none">> Sunroof inoperative.> Faulty sunroof module.> Water dripping from headliner.	Seal incorrectly positioned	Check seal sunroof frame.	STEP 2.1 (see below)

FAULT TRACING AND SERVICE:

There can be different symptoms indicating water ingress into the passenger compartment. The fault tracing steps below will cover most commonly known problems. If the leak is not found after going through these steps, continue with normal fault tracing (AC drainage hoses, front windshield, other...). The different checks are in logical order according to ease of the check and number of parts to be disassembled.

Step 1.1 Check front drainage holes (both sides):



Open the sunroof and check the drainage holes at the left and right front corner from the sunroof cassette. Both holes should be free of leaves and dirt.

Service: remove any dirt or debris.

Step 1.2 Check fitting of the sunroof towards the roof:

Sunroof must be in fully closed position.

Checking the vertical position at front end rear edge of the glass panel:

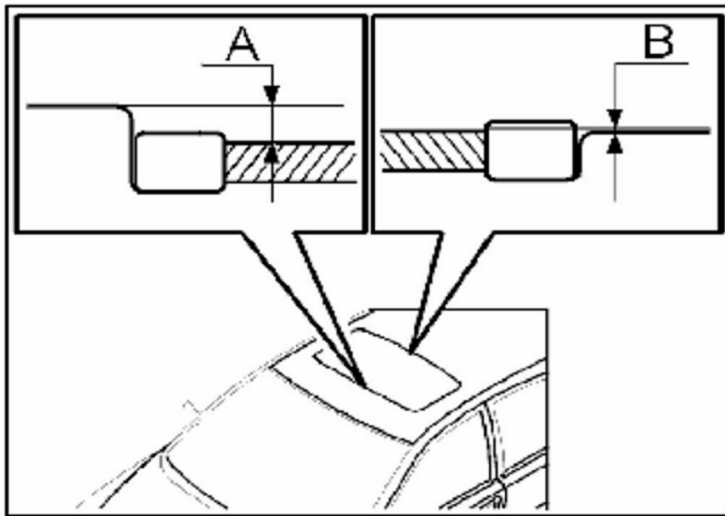

Front edge: The top of the glass must be flush or maximum 0.04 inch (1 mm) under the roof panel. (See dimension A).

Rear edge: The top of the glass must be flush or maximum 0.04 inch (1 mm) above the roof panel. (See dimension B).

Checking the horizontal position of the glass panel:

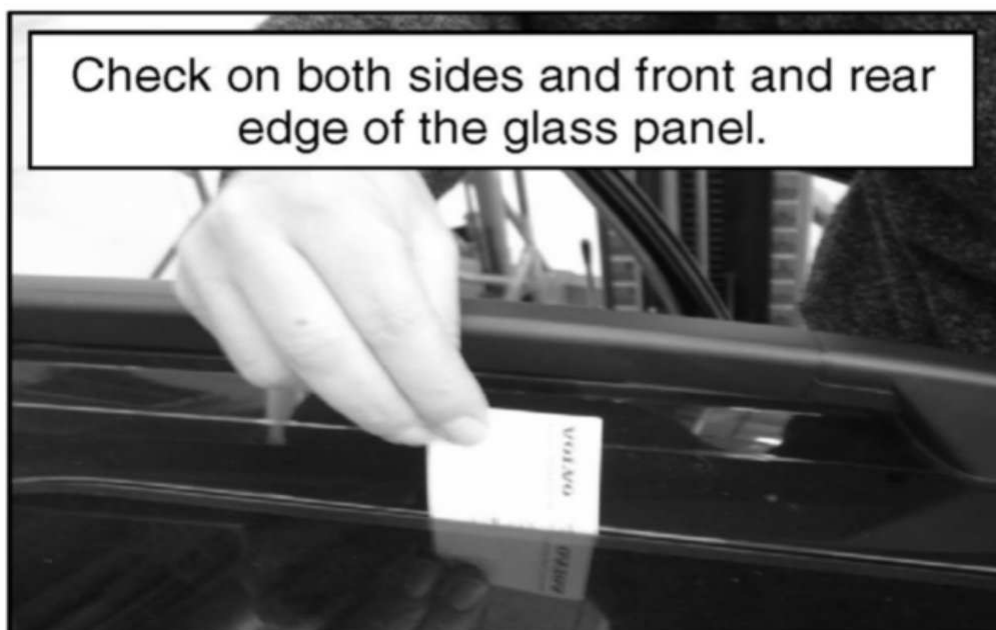

The sunroof must be centered in the opening.
Verify that there is even pressure on the seal on both sides and along front and rear edges of the glass panel.

This can be done visually and with a piece of paper (e.g. business card).
Insert card and pull out to feel the pressure between the seal and the roof plate.

Compare all four sides to determine if the sunroof is not centered.

Service:

If the sunroof fitting is not according to specification, follow instructions as per VADIS for adjustment. (Function Group 8, Repair and installation instructions, Sunroof, adjusting).

Step 1.3 Check front sound traps in the A-pillar (both sides):



Disassemble A-pillar panels according VADIS.
Pull the rubber sound traps out of the holes in the front A-pillars and verify that they are open and clear from debris or dirt.

Verify connection of drainage hose and sound trap.
Make sure the hose is fully inserted.
Verify proper assembly of the rubber grommet on the
sound trap into the hole in the A-pillar.

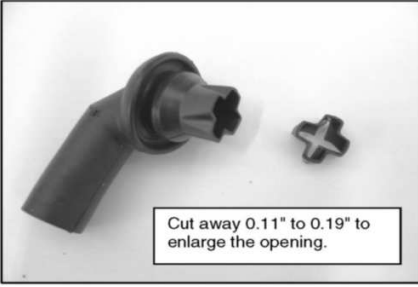
Modification for cars with chassis number between 000690-171367	
<p>A modification for the sound traps in the A-pillar is recommended.</p> <p>Use a scissors to cut 0.11" to 0.19" from the sound trap as shown in the picture.</p> <p>This will enlarge the opening and prevents the sound trap from clogging.</p> <p><i>Cars after the chassis number limits are modified from the factory.</i></p>	 <p>Cut away 0.11" to 0.19" to enlarge the opening.</p>

Service:

Clean the sound traps. Enlarge the opening of the front sound traps on cars with chassis number between 000690-171367.

Step 1.4 Check front drainage pipes along A-pillar (both sides):

Check routing of the hose along the A-pillar and verify that the hose is free of dirt and debris.



Service:

If the hose is clogged, clean or replace the hose.

If the hose is kinked, replace the hose.

Hint:

A similar type of hose with better rigidity than the original hose can be used to avoid kinking.

*Semi-rigid Polyethylene tubing.

Outer 1/2", inner 3/8".

Manufacturer Watts (Part ref # 42141525)

Available at Home Improvement Outlets or an automotive supply store.

Step 1.5 Check upper part of front drainage (both sides):



Disassemble the [sun visors](#) and the front interior light panel according to VADIS.

Release the headliner from the rubber seals in the door opening and the B-pillar panel.

Pull the headliner down to allow inspection of the drainage hoses behind the headliner.

Note : Gently pull down just a little of the headliner to avoid permanent crease marks!

Verify routing and look for possible kinking.
Verify that the hose is clear of dirt and debris.



Service: Replace the hose if kinked or clogged.

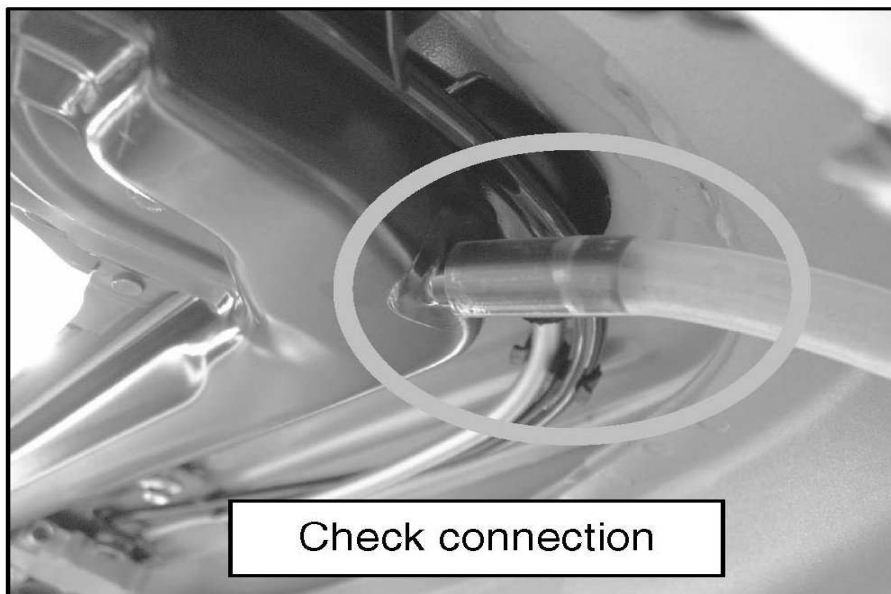

Verify connection between the hoses and the gutter pipes at the front left and right side of the sunroof cassette.

Make sure the hose is pushed all the way onto the gutter pipe.

Step 2.1 Check foam between cassette and roof, front center:

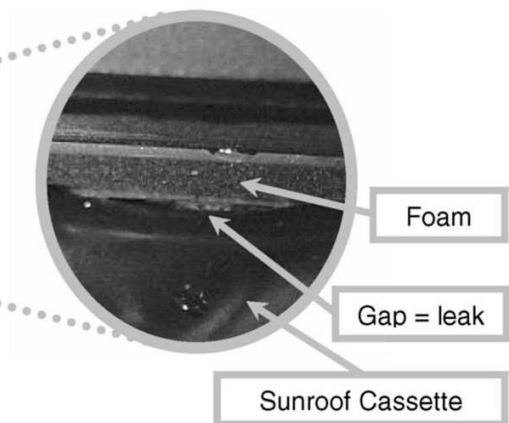

Under certain conditions, a small gap might occur at the foam between the sunroof cassette and the roof plate. The critical area is in the front center where a hole is punched in the sunroof cassette. Check the position of the foam; it should be covering the complete hole.

Service: Use PUR sealant or similar to close the gap.

WARRANTY CLAIM INFORMATION		
LABOR OP	LABOR DESCRIPTION	LABOR TIME
99246-2	A-pillar drain adjustment (2 sides) and drying out the car	2.3 hr
83614-2	Sunroof, adjusting	0.3 hr

Claims may be submitted under the new car warranty when there is a documented customer complaint using claim type: 01

WARRANTY CLAIM INFORMATION