

## 2001 Volvo V70 XC AWD L5-2.4L Turbo VIN 58 B5244T3

### Replacing the Engine Torque Bracket

#### REPLACING THE ENGINE TORQUE BRACKET

#### Removing The Torque Bracket

**NOTE:** As the illustrations in this service information are used for different model years and/or models, some variation may occur. However, the essential information in the illustrations is always correct.

#### Remove

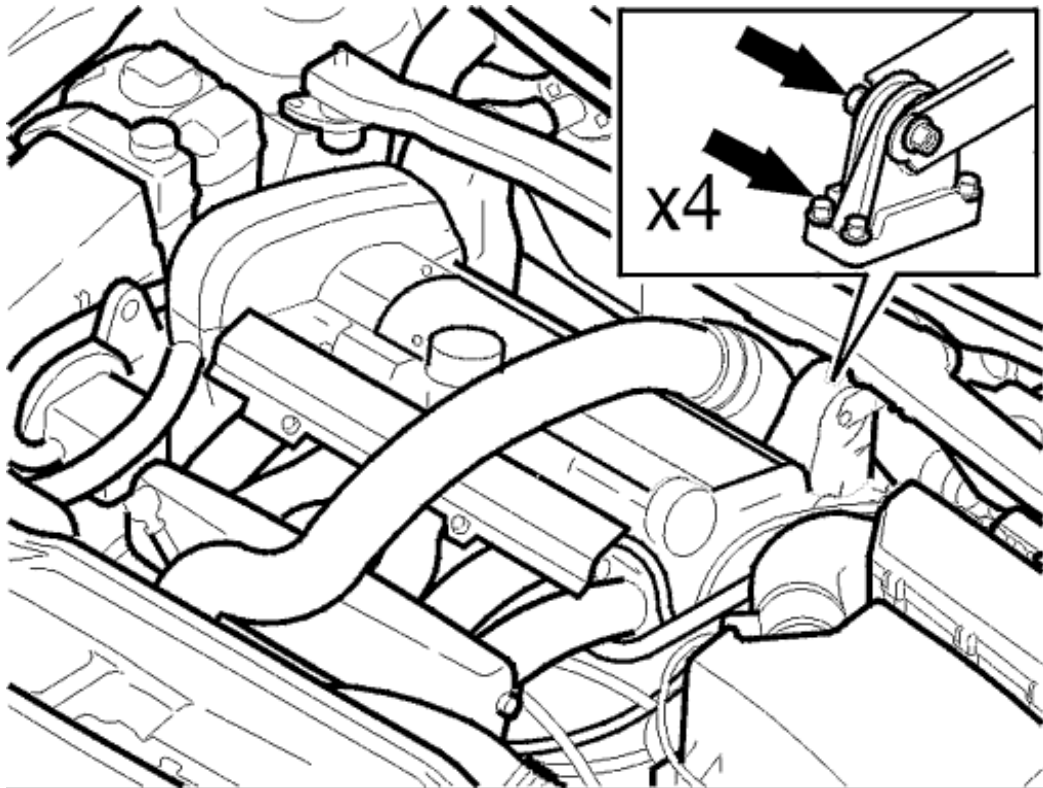

- \* the engine stabilizer brace
- \* the charge air pipe (only turbocharged (TC) engines)
- \* the oil filler cap
- \* the cover over the ignition coils the torque bracket.

## Install

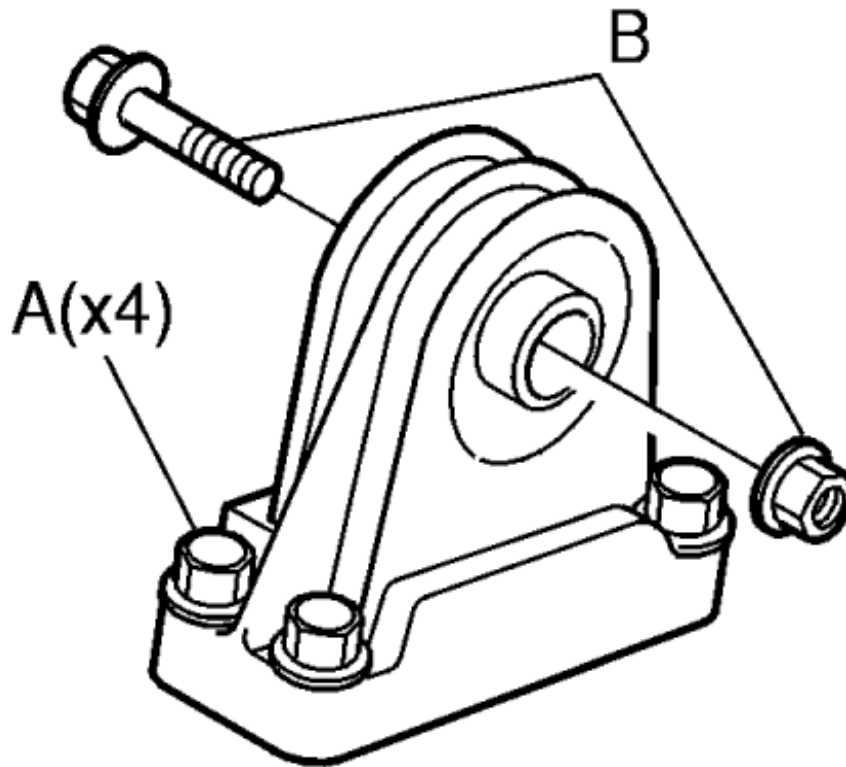

- 
- \* the torque bracket. Tighten the screws (A). Tighten to **50 Nm** .
  - \* the screw for the dip stick pipe.
  - \* the cover over the ignition coils.
  - \* the oil filler cap.
  - \* the charge air pipe (only turbocharged (TC) engines)
  - \* the engine stabilizer brace.

Tighten the screws on the suspension turrets. Tighten to **50 Nm** . Tighten the screw in the torque bracket (B). Tighten to **80 Nm** .