

Drivetrain - Front Driveshaft CV Joint Service

NO: 46-10

DATE: 4-27-2007

MODEL YEAR:

1998- AWD (All Wheel Drive) Cars

SUBJECT:

Propeller Shaft Front CV (constant velocity) Joint Available as a Spare Part

DESCRIPTION:

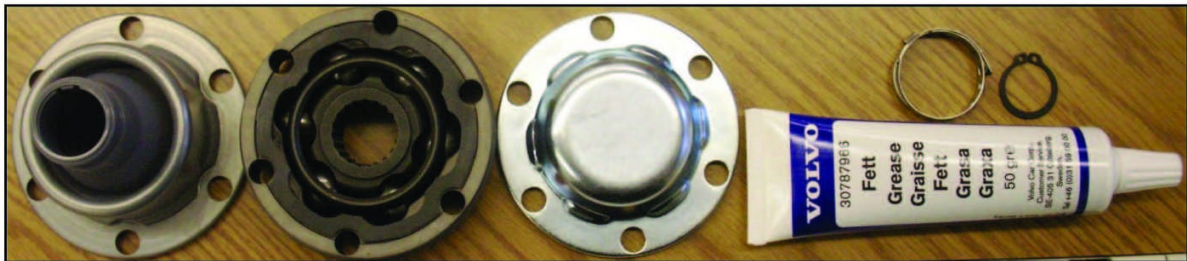

The front CV joint for original equipment propshafts on all AWD cars is now available as a spare part kit. This kit includes the boot, joint W/seals, cover, clamp, lock-ring, seals and grease.

SERVICE:

- S70AWD/V70XC (1998-1999, chassis -465398) PN 30614441, fits original equipment shafts only
- S70AWD/V70XC (1999-2000, chassis 465399-) PN 30651204, fits original equipment shafts only
(A torn boot is a possible failure mode for these variants.)
- XC90 T6 (2003-2005) PN 31216175
(Clicking noise during acceleration when cold may be a customer complaint on this variant.)
- S40/V50 (2005-).....PN 31216175
- S60/V70AWD 2.4 (2002)...PN 31216175
- S60/V70AWD 2.5 (2003-)...PN 31216175
- S60/V70R (2004-).....PN 31216176
- V70XC 2.4 (2001-2002)....PN 31216175
- XC70 2.5 (2003).....PN 31216175
- S80 3.2 (2007-).....PN 31216177
- S80 V8 (2007-).....PN 31216176
- S80AWD 2.5 (2005-2006).....PN 31216175
- XC90 2.5 (2003-2006).....PN 31216175
- XC90 3.2 (2007-).....PN 31216176
- XC90 V8 (2005-).....PN 31216176

For reference purposes, the joints are physically marked as follows:

- PN 31216175, marked HLJ75
- PN 31216176, marked LJ75
- PN 31216177, marked BJ75L



If the joint has failed, replace it according to the instructions in VIDA. Be sure to mark the rear flange of the shaft in relation to the flange on the rear axle, to prevent a vibration. Note that on some variants, different length bolts may be used at the rear for balancing purposes, and they should be installed in the same position they were removed from. The entire shaft should only be replaced if the center bearing has failed or if the tube is physically damaged.



Note: When handling a propeller shaft out of the vehicle, it is important to support it so that the boot on the center joint is not damaged. Allowing the shaft to fold at the center joint may cause the boot to be cut by the edge of the joint.



Note: It is normal for the front & rear joints to feel stiff when the propeller shaft is out of the vehicle. (These are not the same type of joints as the ones used on front axles.)

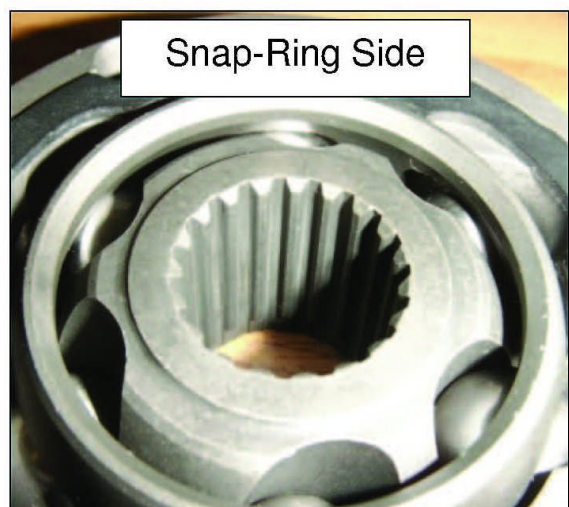
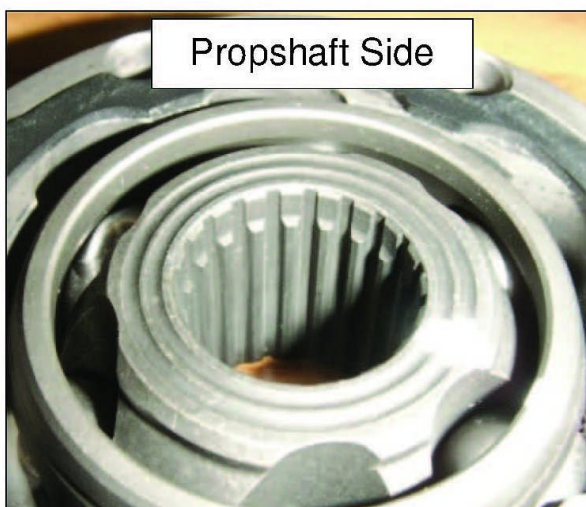

Note: The joint is not symmetrical. It should be installed according to the pictures.

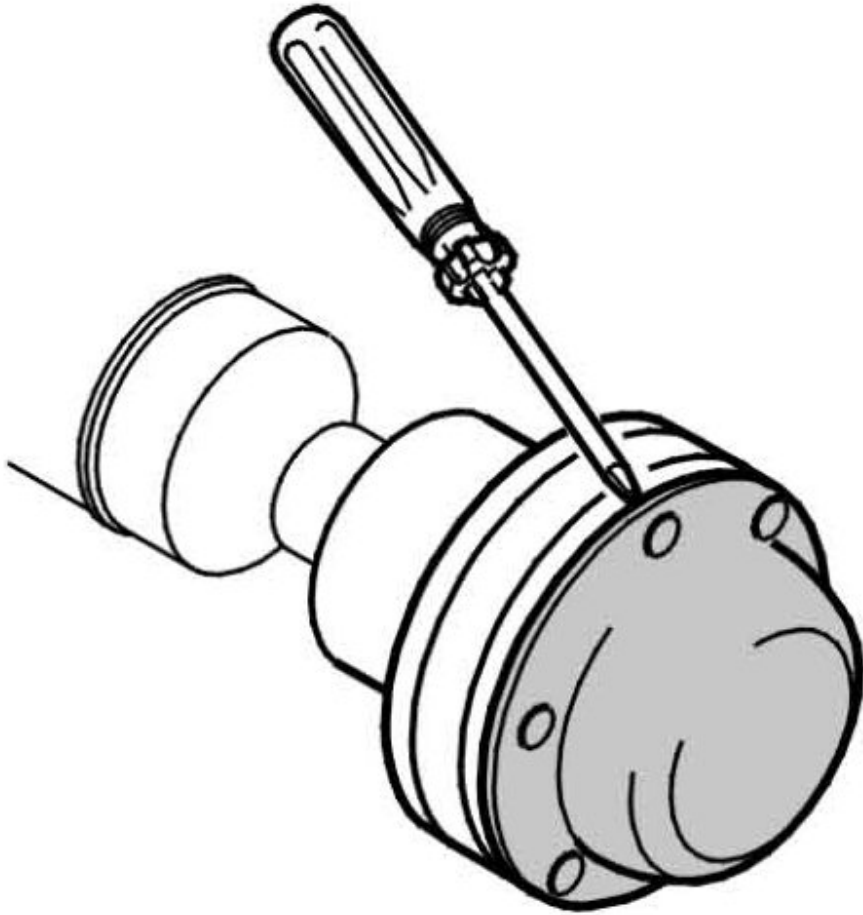

1. Pop off the front cover using a screwdriver.

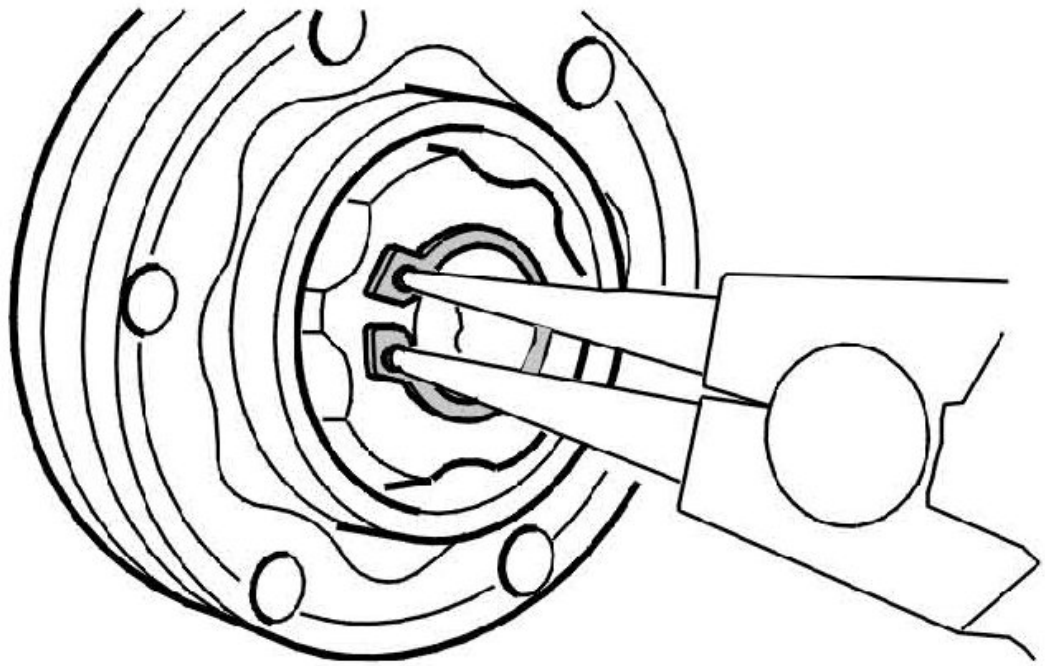

2. Remove the snap ring.

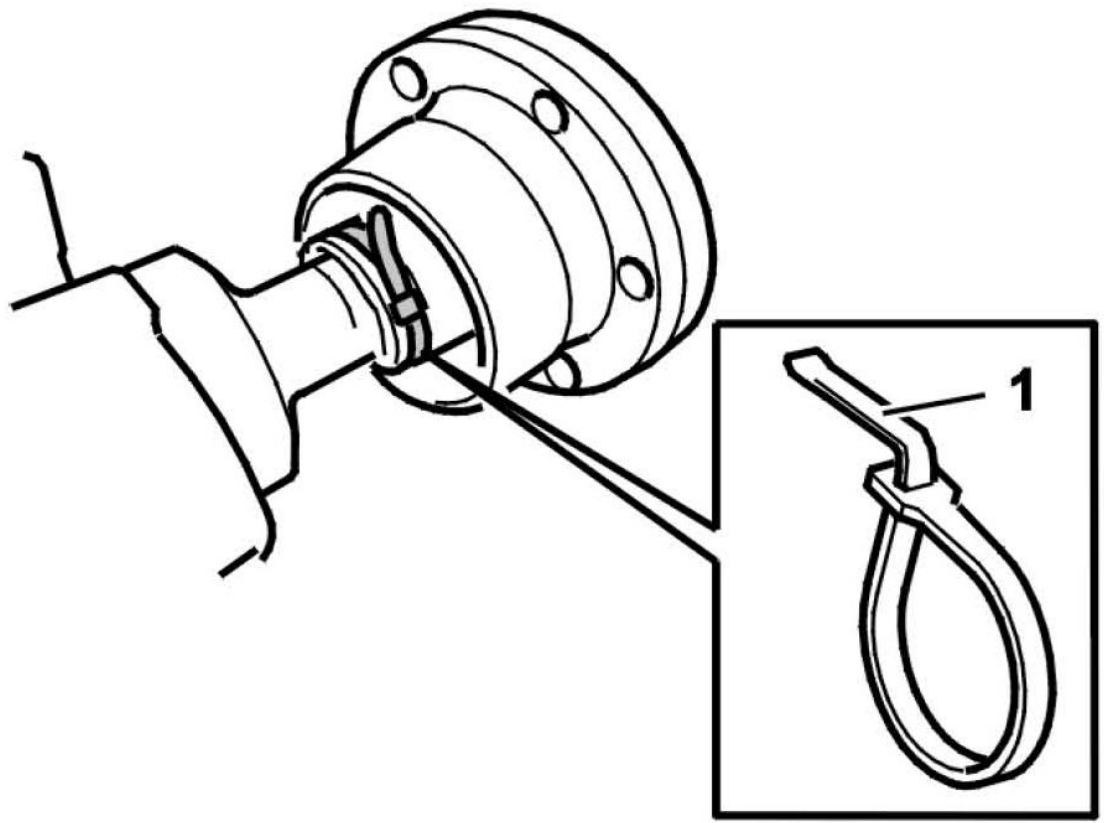

2. Remove & discard the boot clamp (1).

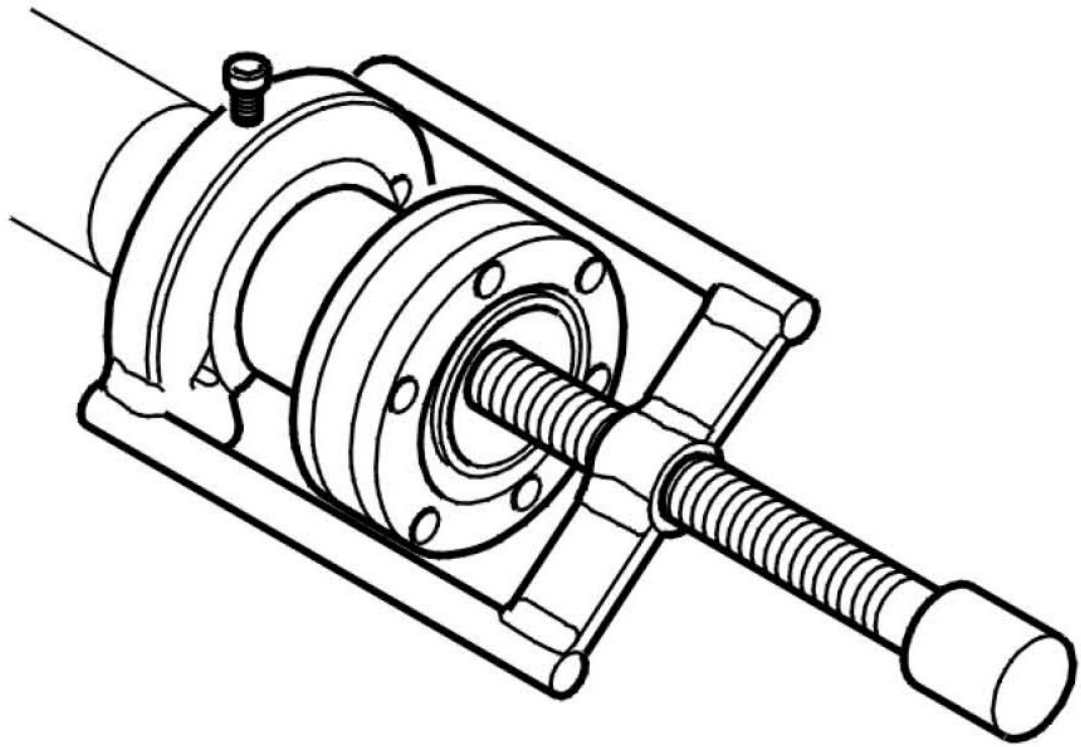

3. Remove the joint from the shaft using puller 999 5427 or knock it off using a plastic mallet.

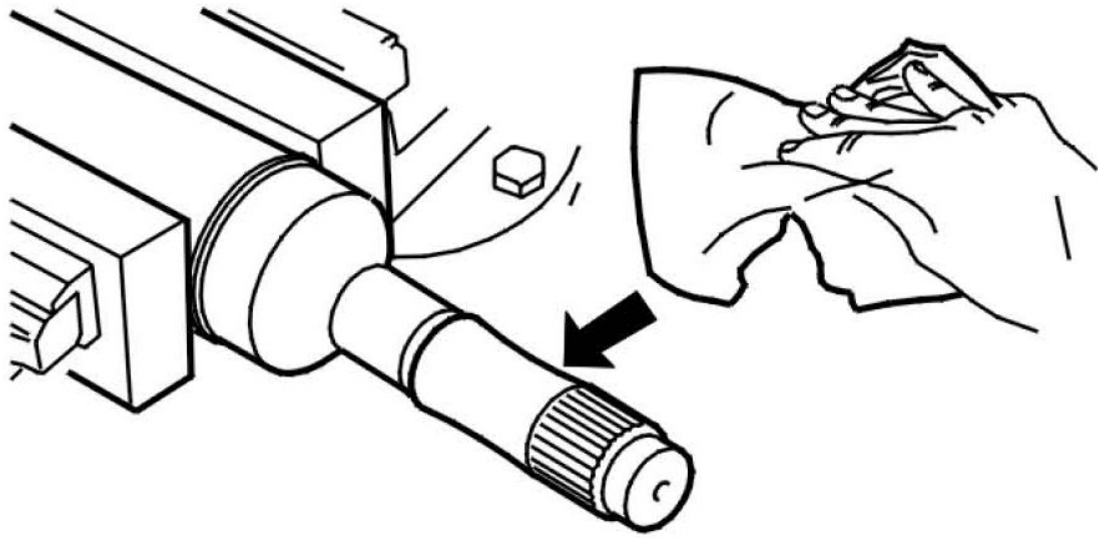

4. Clean the shaft and splines. Drop the new boot clamp onto the shaft.

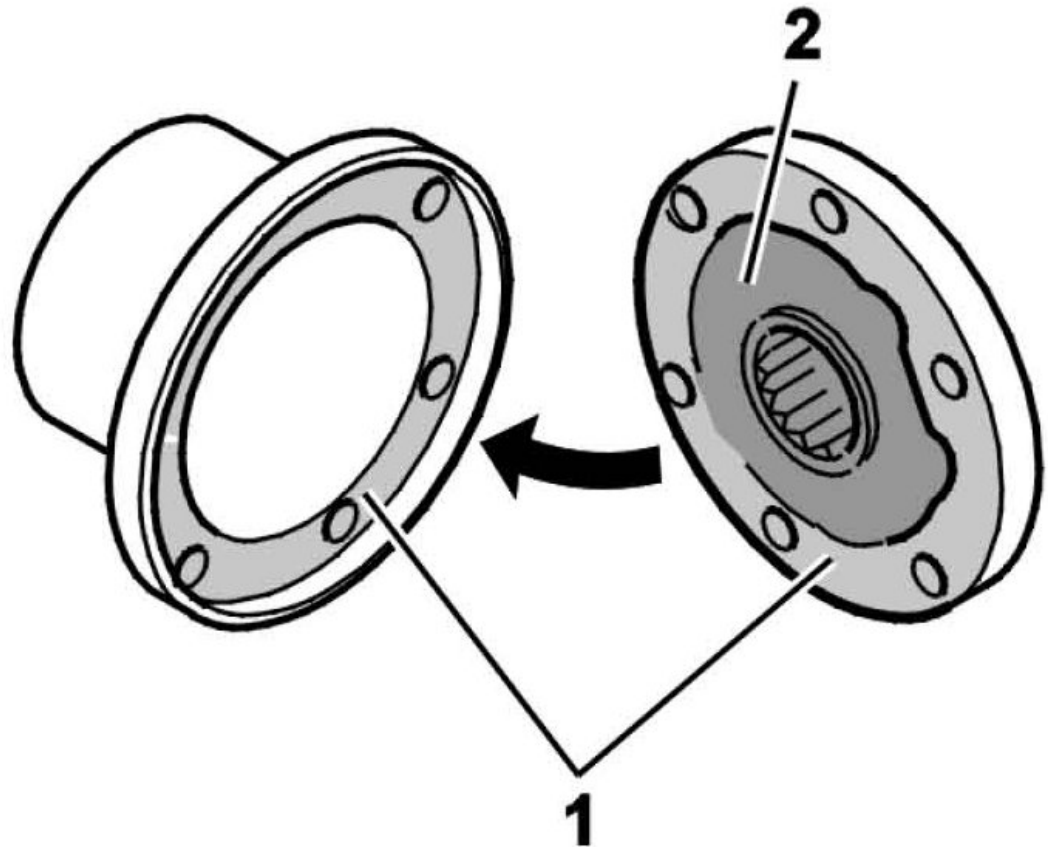

5. Check that there is a gasket on each side of the joint & that they are properly positioned. Squeeze the grease into the joint (2). There must not be any grease on the mating surface (1). Install the boot on the joint. Ensure that the holes are aligned.

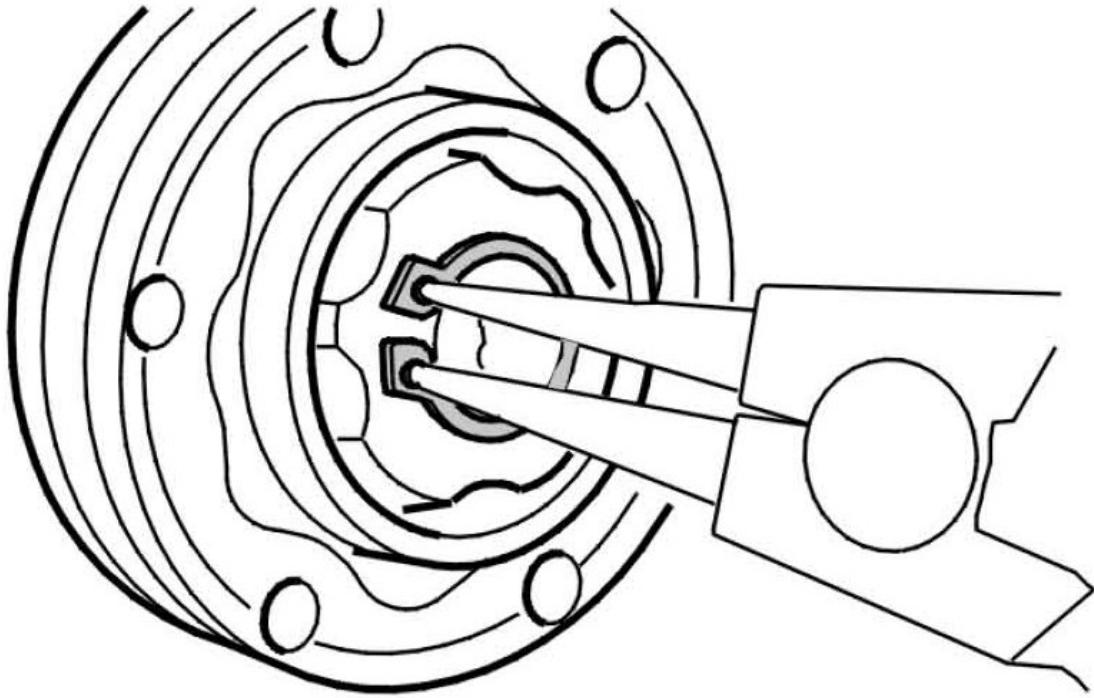

6. Install the joint on the shaft. knock it into place using a rubber mallet. Use a socket as a spacer. Install the snap ring. Check that it is in the groove.

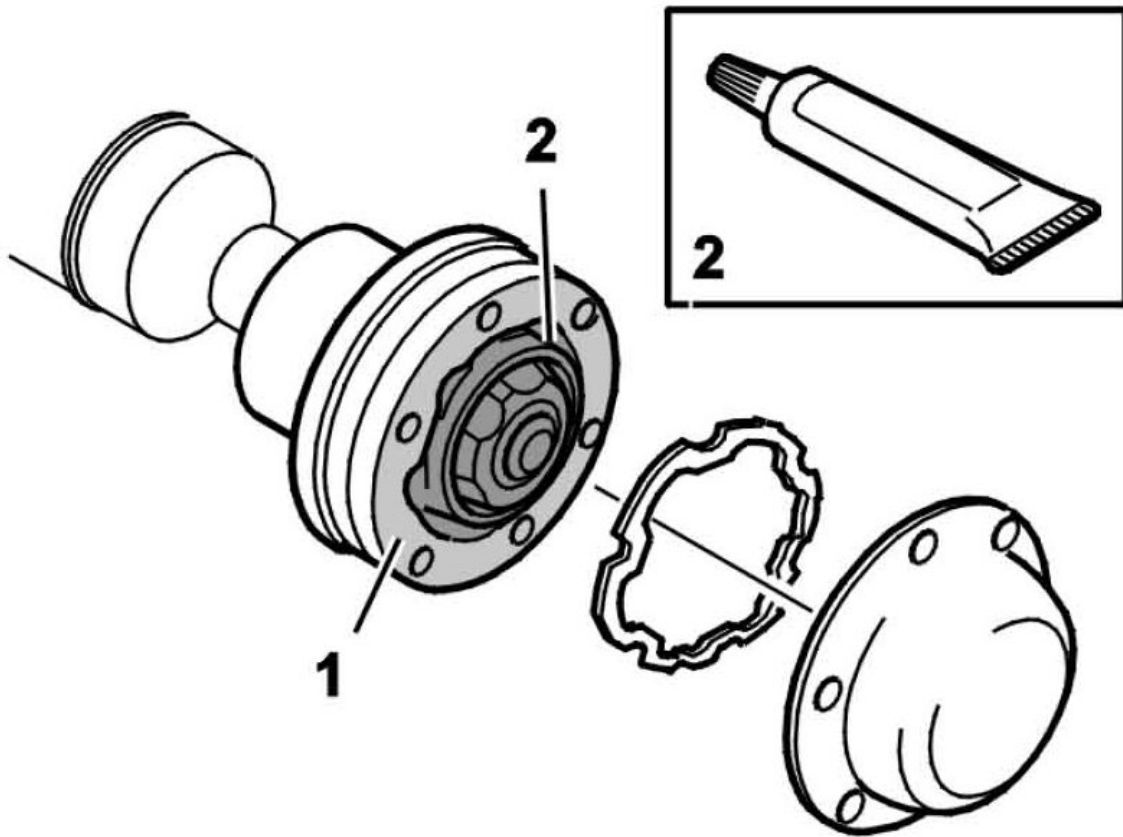

7. Squeeze the remaining grease into the joint (2). The entire contents of the tube must be used.

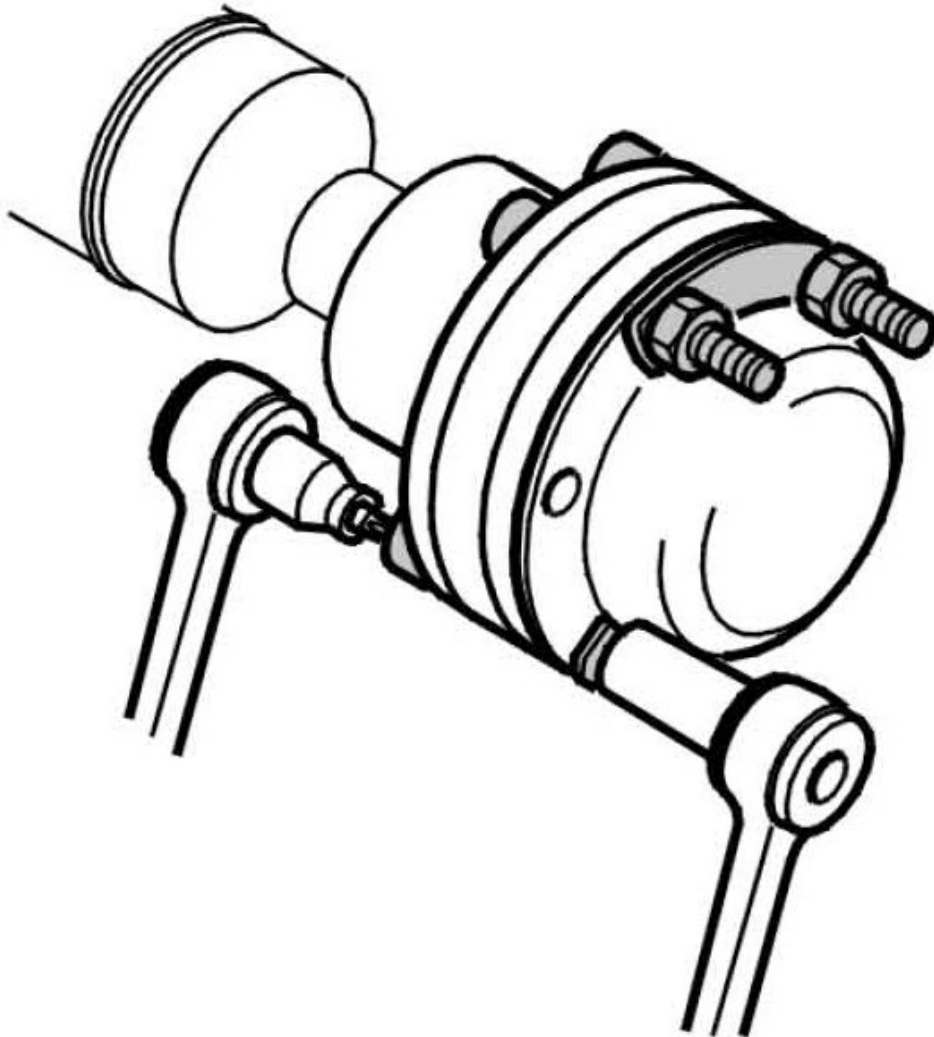

8. Press the cover onto the joint, using 2 washers, 4 screws and 4 nuts. Tighten crosswise until the cover bottoms on the joint. Remove the screws, nuts and washers.

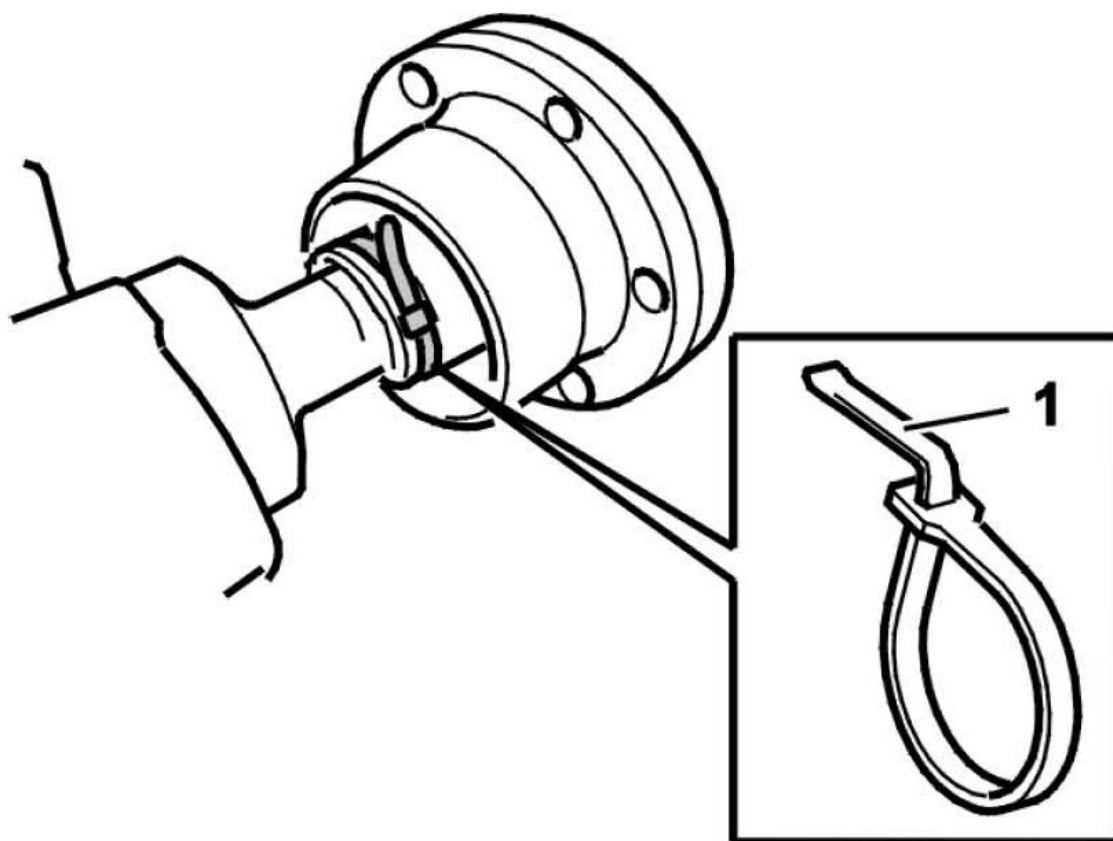

9. Press the air out of the boot. Ensure that the boot is positioned correctly on the shaft. Install the new clamp (1).

WARRANTY CLAIM INFORMATION		
LABOR OP	LABOR DESCRIPTION	LABOR TIME
45122-3	Propshaft, Front CV joint replace (This is in addition to propshaft remove/install.)	.6

Claims may be submitted under the New Car warranty when there is a documented customer complaint using claim type: 01