

Dashboard, Replacing

Dashboard, Replacing

NOTE: As the illustrations in this service information are used for different model years and/or models, some variation may occur. However, the essential information is always correct.

Removing the dashboard

Remove the battery lead.

Remove (on both sides):

- the A-post panels.
- the soundproofing panel.

Slide the seat backwards.



- the courtesy lighting on the driver's side.
- the on-board diagnostics connector.
- the steering wheel.
- the gear selector assembly.
- the combined instrument panel.
- the center console.
- the radio.

HINT: Disconnect the mechanical cable for the gear lever lock to facilitate removing the dashboard.

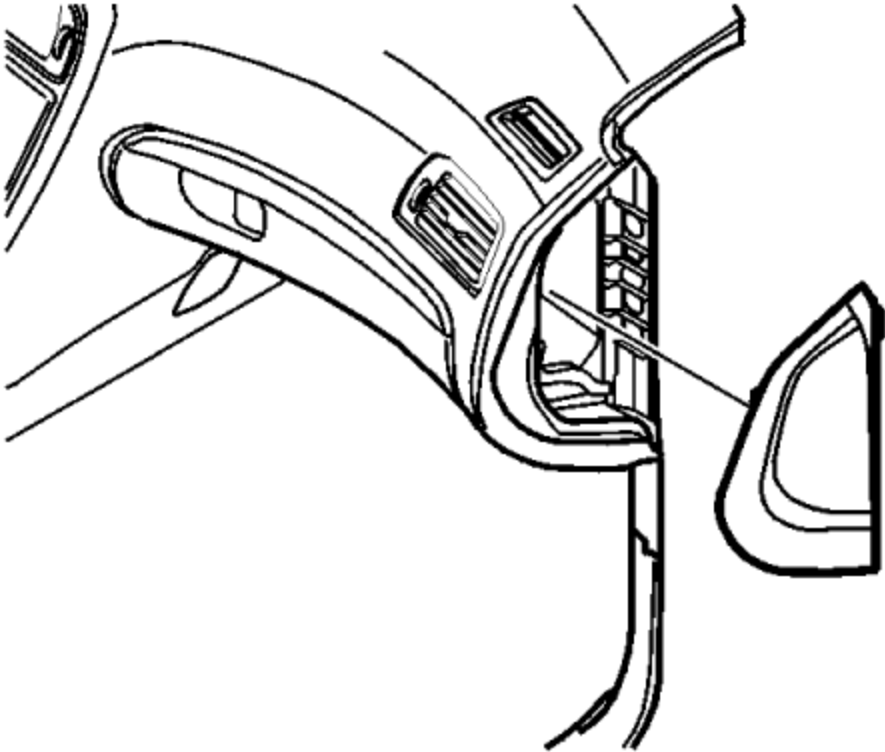

Remove the end covers on both sides.

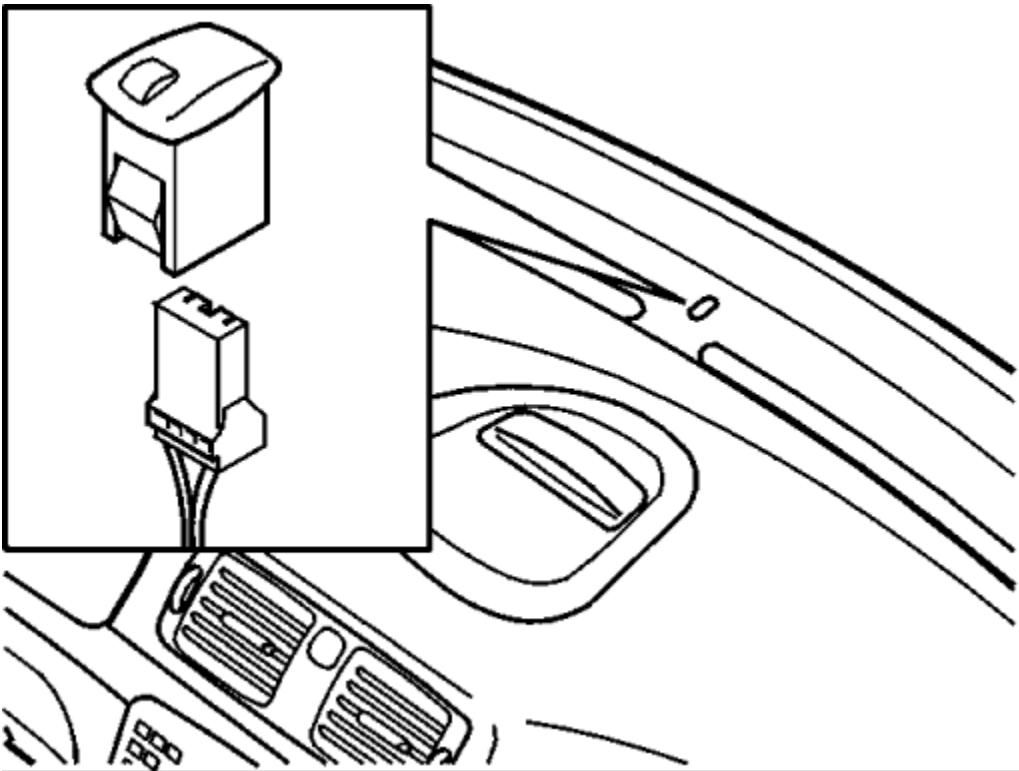

Lift up the sun sensor. Disconnect the connector. Remove the sun sensor.

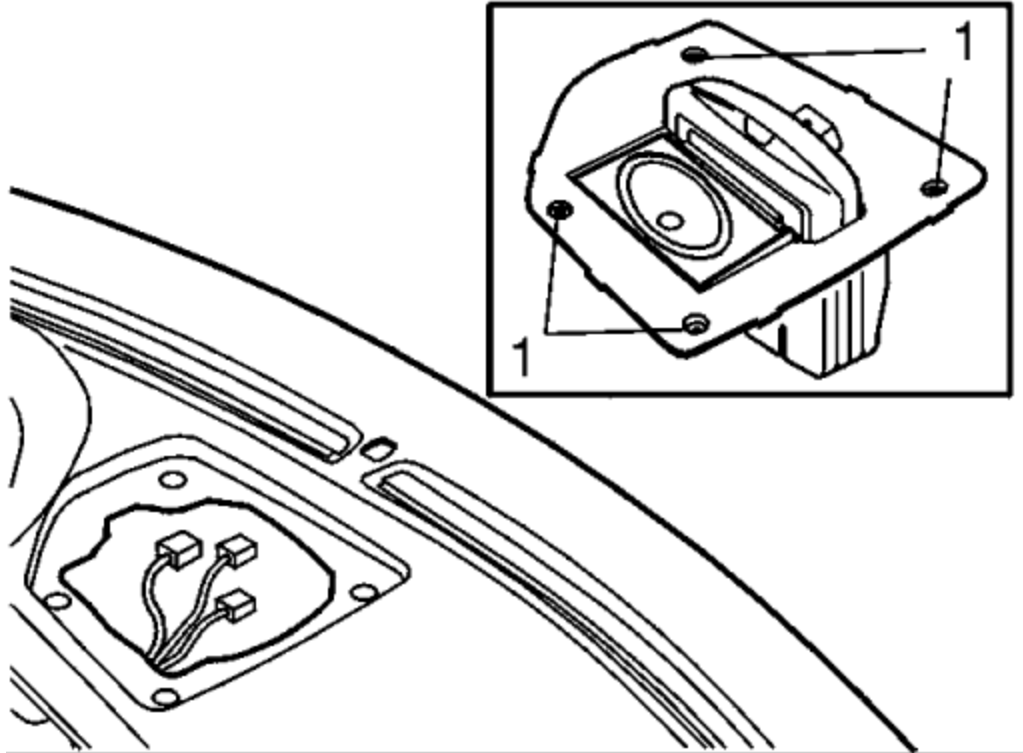

Remove the road traffic information (RTI) screen/loudspeaker.
Disconnect the connector for the hazard warning signal flasher.
Open the [glove compartment](#). Release the limiter stop.

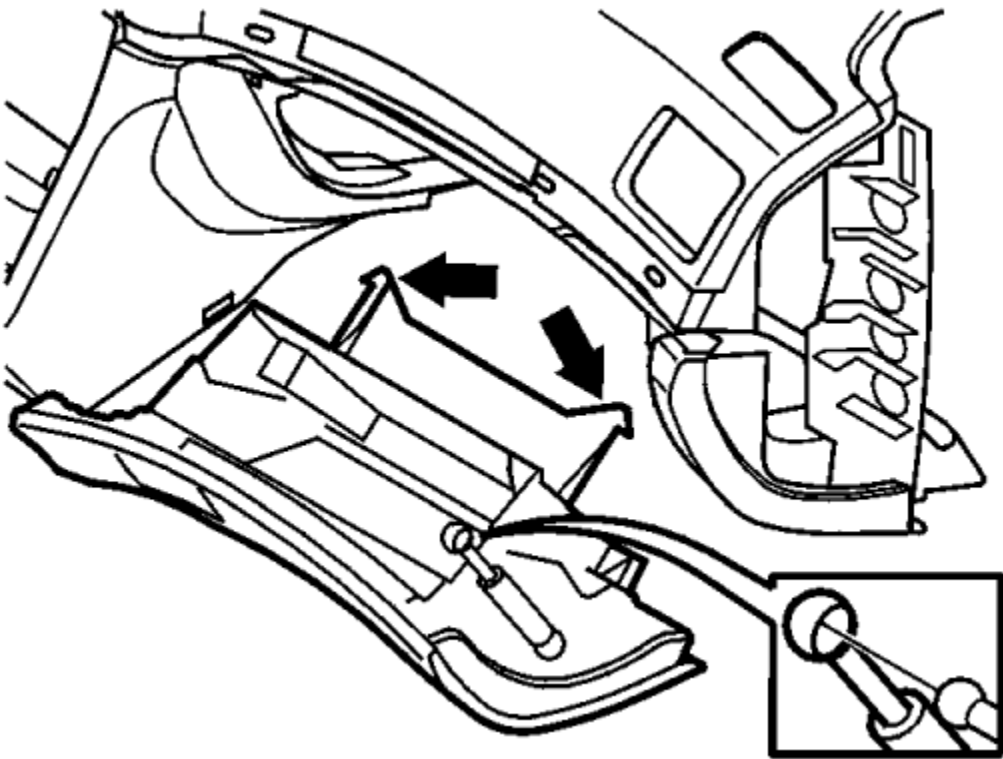

- the upper mounting for the gas strut
- the connector for the courtesy lighting
- the connector for the glove compartment lighting
- the connector for the passenger airbag module.

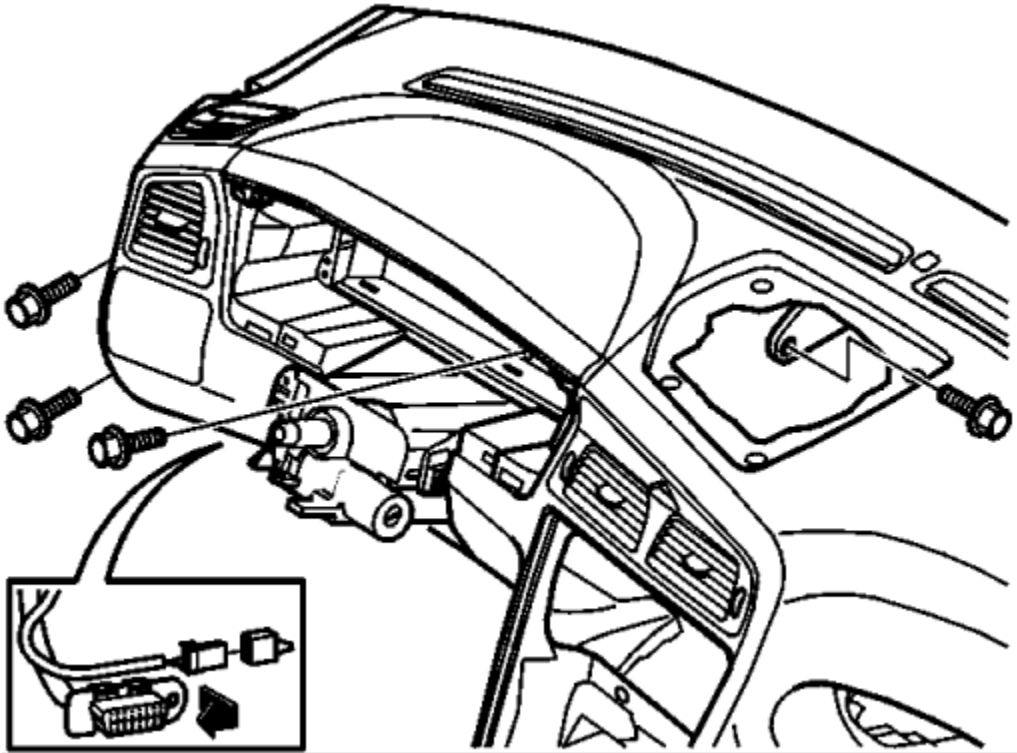

- the three mounting screws for the dashboard on the driver's side
- the screw for the mounting for the dashboard in the opening for the road traffic information (RTI) system.

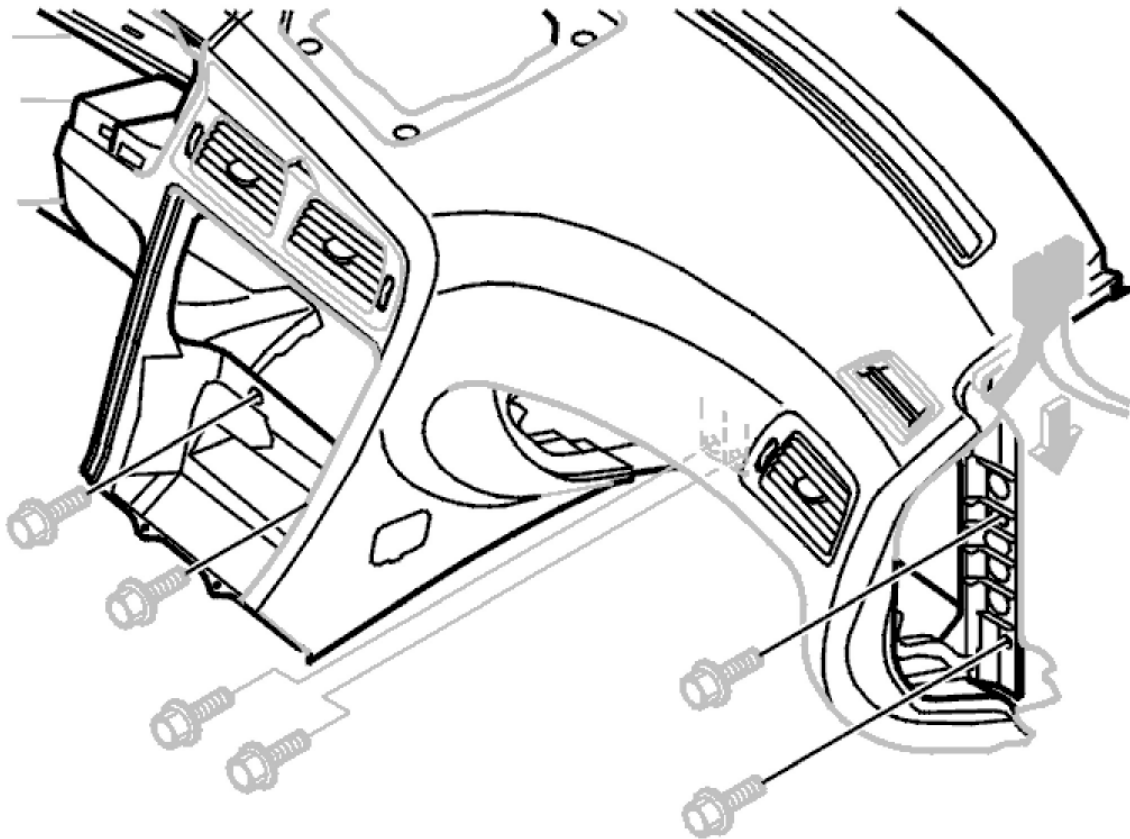

- the four mounting screws for the dashboard on the passenger side
- the two screws for the mounting for the dashboard in the opening for the dashboard environment panel.

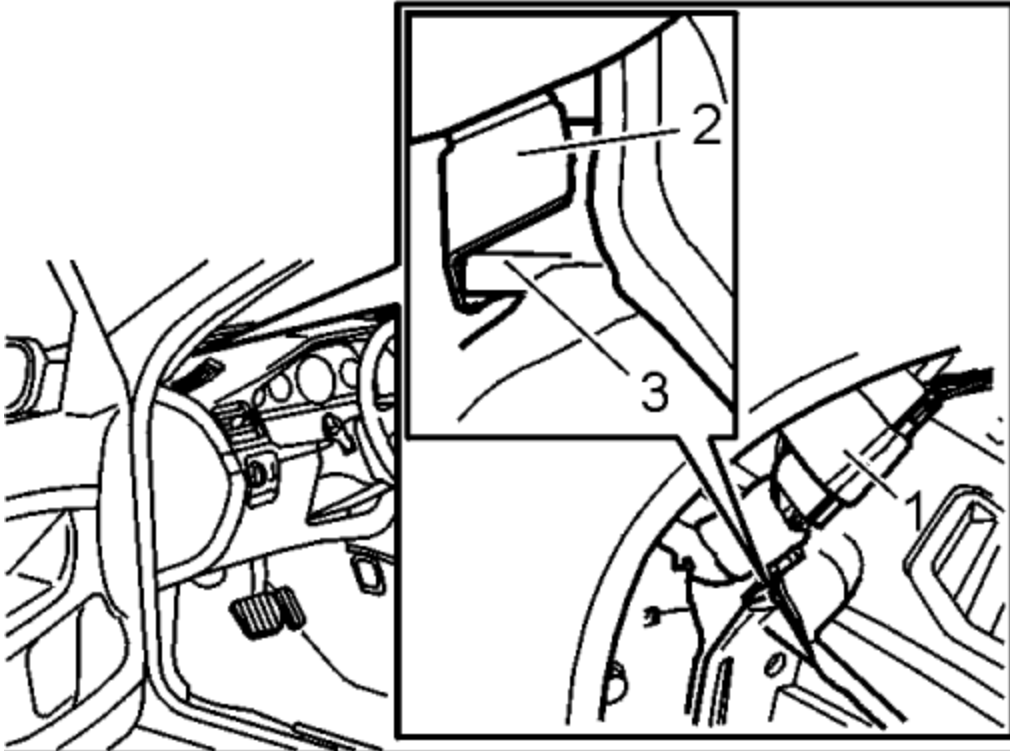

Pull the dashboard back slightly so that the brackets for the connectors at the A-post can be removed.

Move gear selector lever backwards.

NOTE: Protect the gear selector lever knob using tape.

Pull the dashboard backwards. Lift the dashboard over the gear selector lever.

Lift out dashboard.

Transfer the ventilation vents.

Installing the dashboard

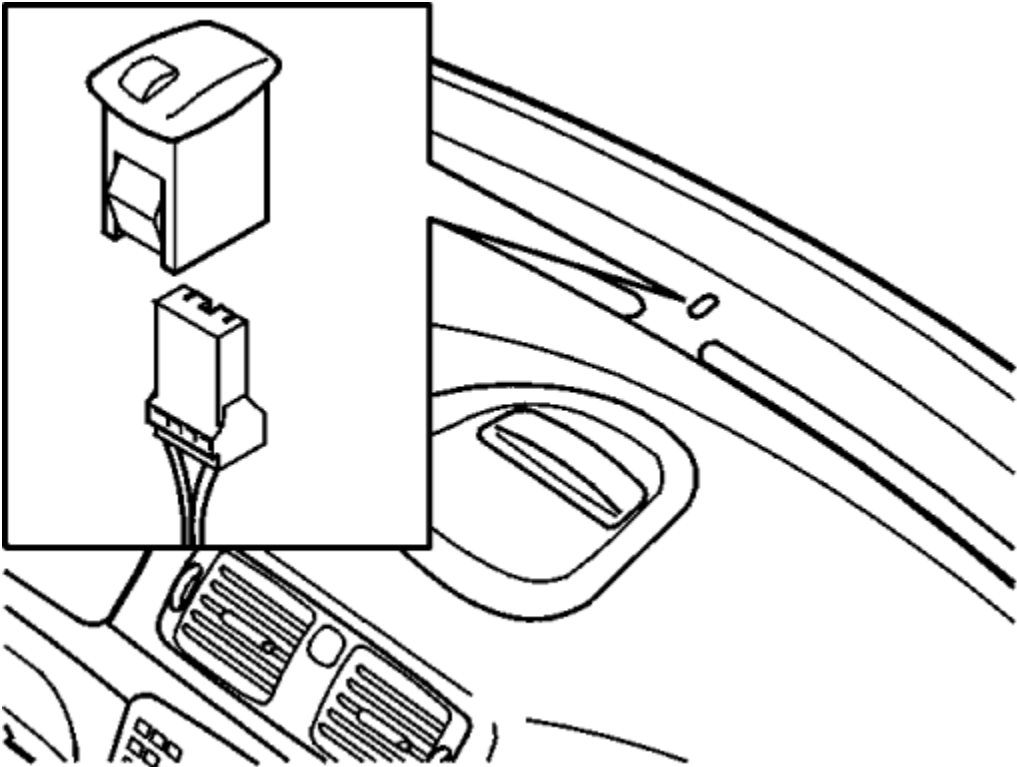

- Lift the dashboard over the gear selector lever.
- Install the brackets for the connectors at the A posts.
- Pull the connector for the sun sensor out through the hole in the dashboard.
- Press the dashboard into position.
- Install the 10 screws (Tighten to **10 Nm**).
- Close the [glove compartment](#) lid sufficiently for the gas strut to be installed.
- Press the gas strut into place.

Install:

- the sun sensor
- the connector for the hazard warning signal flasher
- the display screen/loudspeaker.
- the end cover
- the mechanical cable for the gear selector lever knob
- the radio.
- the center console.
- the combined instrument panel.
- the gear selector assembly.
- the steering wheel.
- the on-board diagnostics connector.
- the courtesy lighting on the driver's side.
- the soundproofing panels.
- the panels for the A-posts.

